

THE SPIRIT OF ART



IN TECHNOLOGY

CLASS 'A'

Exposed & Explained

A Technical Rap
for Musicians:
“How Amps Work”
— AND —
“What is Class A?”

Randall Smith
MESA ENGINEERING

©2005 All Rights Reserved.



Randall Smith
MESA ENGINEERING

INTRODUCTION

Grab a glass of your favorite beverage and prepare to hang out. These are big, tough topics we'll be dealing with and hopefully you'll find this informative and enjoyable reading ... especially because there's no mandatory test on Friday!

Two topics I'm often asked to explain are, "What is Class A" and "What are the differences between the Lone Star and its brother, the Lone Star Special".

Because the two amps are the same except for their power sections, we can combine both those questions so that each one helps to explain the other. And when you get a chance to audition the two amplifiers, you'll be treated to a demonstration of the musical impact of all the technotalk you're about to read. You'll be able to directly compare Class A to Class AB, single-ended to push-pull, as well as the inherent sonic differences between 6L6 and EL-84 power tubes. School was rarely this much fun!

But hang on because this stuff is pretty deep and no one can expect to understand it all in one shot. I've worked with it and thought about it for decades and still have lots to learn. It's more likely that each time you delve into it, one or two more things will make sense and your understanding will grow step by step. A little like learning to play an instrument.

First, the overview of the two amps: The Lone Star Special includes all of the features of the original Lone Star except Tweed Power. (You'll see why there's no need for Tweed in a minute.) The Special has the same two-channel pre-amp including the switchable Drive mode for Channel Two; the gorgeous Reverb, with its own Bright switch; the all-tube FX Loop with the hard-bypass relay (which totally removes the two Send and Return tubes plus their Level controls and jacks from the signal path); the switchable fan; the aluminum chassis and so on, just like its Big Brother.

But whereas the Lone Star uses four big 6L6 output tubes with channel-assignable power switching of 50 or 100 watts, the Special uses four EL-84s, the crunchy little nine-pin power punks. Each style of power has its own musical virtues, and many players will want both amps.

The 6L6s put out huge, airy warmth with shimmering highs and enough clean headroom to play almost anywhere. These power tubes are run “push-pull, Class AB”, two for 50 watts, switchable to four in “push-pull-parallel” for 100 watts, still Class AB.

The EL-84s in the Special sound a little more brash and rebellious with their chimney top-end. Again they’re switchable, this time between three different power levels: 30, 15 or 5 watts, assignable per channel. These power ranges are perfect for individual playing, recording and gigging

up to mid-size venues. And the different output and break-up characteristics of the three power levels is incredibly rewarding.

The EL-84s are run pure Class A for the maximum in vintage warmth. In the 30 watt position, all four tubes are operating in a push-pull parallel configuration. Then one

pair can be switched off to provide 15 watts from the remaining two tubes. But what makes this amp truly Special is the way it can also kick down to just one EL-84 for five watts of preciously nuanced, single-ended, Class A power bliss (patent pending).

OK, the rap sounds familiar, you’ve heard most of these terms before because salesmen like to toss them out to get you hyped on an amp ...and perhaps a little intimidated as well. Players usually nod their heads knowingly, thinking, “Yeah, Class A. That’s the best. Isn’t it?” But few players ever have the nerve to toss it back and ask for a real explanation. And for good reason, too! The salesman probably doesn’t know much more than you do! Yet after reading this (a couple of times) you’ll be way ahead of the crowd.

EL-84s are run pure Class A for the maximum in vintage warmth.

OVERVIEW

The most important thing for a musician to understand is that the different amplifier Classes and Configurations serve different purposes and styles. No one is flat-out better. A player looking for maximum clean headroom will want a Class AB, push-pull amplifier because power is its forte. A player seeking a certain vintage vibe may well prefer a Class A amp, but no matter what tube is used, it will definitely be less powerful.

Either type can be made to sound warm and lush or brash and biting – mostly as a result of other important factors such as the pre-amp and driver circuitry, transformer and component choices and, of course, speaker options. (Of no demonstrable importance is whether it was wired point-to-point or on a well done printed circuit board.) Tube type is vital: EL-34s, 6L6s, EL-84s, 6550s all sound different (especially when clipping) and even different brands of the same tube can sound shockingly different. So if you want to know more about the technical classes, please read on and enjoy. But remember: the most important thing about any amp is what it does for You!

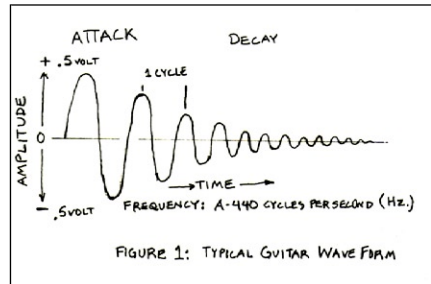

FIGURE 1 illustrates a guitar-note waveform. The vertical scale shows the amplitude (or amount) of signal, as measured in volts. The horizontal scale represents time. As you can see, the frequency remains the same (A-440) even though the amplitude decays rapidly after the attack, exactly like the string vibration. This electrical waveform of that voltage (as you would see it on an oscilloscope) would actually look very much like a picture of the actual string vibration.

OK, TIME FOR SCHOOL!

Let's start by making an important distinction between "class of operation" and "power configuration". These are two separate concepts that describe two different aspects of an amplifier and how it works. Most people mix them together and that only adds to the confusion, even

though they are related. So let's try to straighten it out by explaining each one separately. These terms are usually used when describing the power output section of an amplifier because that's where the differences occur. Nearly every pre-amp circuit ever used is the same in that they are all "single ended" and "Class A".

CONFIGURATION

Configuration refers to the number and arrangement of the tubes. The common terms for describing power tube configurations are "single-ended", "push-pull" and "parallel". In single-ended, the entire signal runs through a single path and is amplified by one tube at a time. Picture your guitar cord: it's single-ended. There is only one conductor (plus ground) that carries the entire signal, swinging back and forth between plus and minus voltages as the string moves back and forth across the pickup. And as that voltage goes through the pre-amplifier stages, it remains single-ended. In a few amplifiers even the output section is single ended with just one power tube – like an old Fender Champ with its one 6V6 power tube. And of course that 5-watt position in the Lone Star Special. Mostly single-

ended power is used for economy but it also has some very interesting and unique tonal characteristics we'll talk about later.

The much more common power configuration is "push-pull". Here the signal is first split into two halves, 180 degrees "out of phase" with each other. The "pluses" are amplified by one tube, and the "minuses" are amplified by

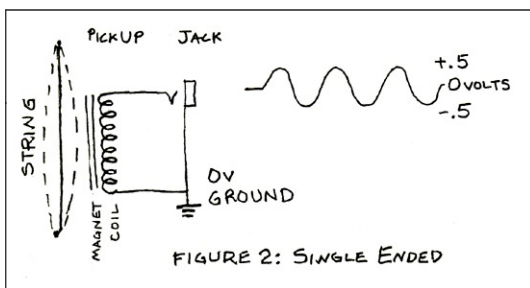

FIGURE 2 shows a guitar string vibrating 440 times per second over the pickup, which is made of hundreds of turns of hair-size wire wrapped around a magnet. The movement of ferrous metal (iron) in the string generates a voltage in the pickup wire by disturbing (or "modulating") the field of the permanent magnet. This is an example of a "single-ended" signal. For clarity and simplicity, we'll no longer show the amplitude decaying.

another tube. Then the two signal halves are “recombined” in the output transformer back into a single-ended voltage to drive the speaker. (Picture a shower faucet with separate Hot and Cold valves where the water mixes together and all comes out of one spout.)

Most power amplifiers use the push-pull configuration because it enables the output tubes to operate much

more efficiently – producing more power from fewer tubes with less waste heat, and we’ll explain how a little later. Meanwhile, note that push-pull requires two power tubes minimum though additional pairs may be added “in parallel” to increase the power. That is why you always see two, four, six or sometimes more big power tubes in an amplifier, but always an even number.

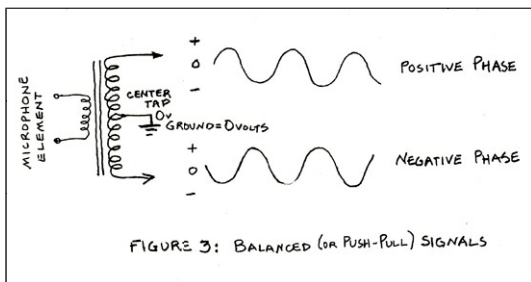

FIGURE 3: BALANCED (OR PUSH-PULL) SIGNALS

FIGURE 3 shows a balanced microphone output. Placing the ground in the center of the coil creates two separate “single-ended” signals of opposite phase. The top half of the coil works just like the example of Figure 2. The bottom half is similar but because it is “up-side-down” – with ground at the top of that section of coil, the voltage swing is also “up-side-down” and therefore 180 degrees out of phase. Thus as the voltage swings positive in the top half, it simultaneously swings negative in the lower half. Merely relocating the “zero voltage” reference point of ground to the center tap creates the balanced “push-pull” signal halves.

HELPFUL DIGRESSION

Push-pull is very similar to a balanced microphone output. That signal is also split into two opposing phases and is carried in two separate conductors (plus a ground). The reason here is for noise cancellation. Microphones have a very low output voltage that must be amplified many times to become useable. The weak signal plus the high amplification required means that noise picked up by the mic cable becomes a big problem. This noise is made up of stray AC electro-magnetic fields that are everywhere in the modern world and they show up mostly as small 60 and 120 cycle voltages that are “induced” into the mic cable.

(“Induced” means the cable functions as the “secondary winding” of a transformer, converting the stray magnetic fields into small electrical voltages that sound like buzz and hum.) Even a well shielded cable will pick up objectionable levels of noise so the solution is to accept that noise is unavoidable and solve the problem by canceling it out at the mixing board. Here’s where push-pull or “balanced” operation saves the day. Splitting the signal into two balanced halves includes reversing the phase of one half while retaining the phase of the other half. Say the original signal’s phase went + to - to +. One wire would remain just that way.

Meanwhile the other wire with its phase inverted would simultaneously be going - to + to -. In the process of recombining the two signal halves back into single-ended, the “out-of-phase” component reverses back to its original phase and is added back to the in-phase component. If it remained out-of-phase when it was recombined, the pluses and minuses would cancel out each other and the whole signal would disappear. These phase changes are caused simply by relocating the “0” voltage reference point from the bottom of the transformer coil to the center, as shown in the drawings.

So as a result of these phase changes, any voltages that show up “in phase” on both conductors at the same time, are later cancelled out because they become “out of phase” with each other later on, when they’re recombined into single ended. Since both conductors in a balanced mic cable pick up the identical noise components, they totally cancel each other out when they are reconstituted. The process is called “common mode rejection” and the sole purpose for the balanced cable system is simply noise suppression. Humbucking pickups also use the phase-canceling principle to reduce noise. This digression is included because most musicians instinctively know something about balanced mic cables and humbuckers even if they don’t know

exactly how they work. And it's a good introduction to push-pull, especially since that cancellation process will become important when we discuss the different sound characteristics between the distortion harmonics of push-pull and single-ended power amplifiers a little later on.

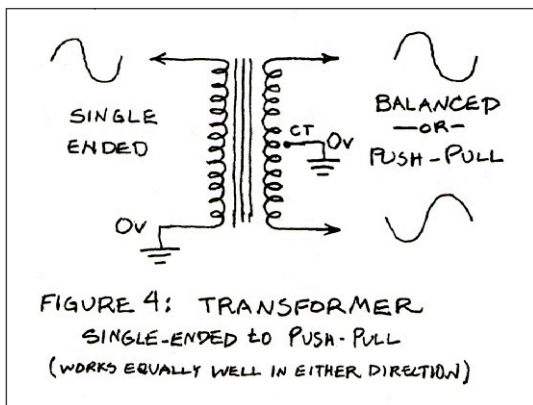

FIGURE 4 shows a transformer for converting between single ended and push-pull. It works just as well in either direction. The mic system might have one of these at each end to convert from single-ended to balanced for the cable then back to single-ended for the board. In a push-pull amplifier, the power tubes would be on the balanced side and the speaker on the single-ended side, since that's the kind of device it is.

MORE ON CONFIGURATION

Parallel simply means additional identically wired tubes are added to increase the power, either single-ended or push-pull. But as a practical matter, single-ended parallel is almost never used and here's why: Even though adding a second tube in parallel with a single-ended circuit will double the power, the same two tubes wired instead for push-pull can triple the power, or more. And the reason for that difference has to do with that other term: the Classes of Operation, so let's discuss that next.

CLASSES OF OPERATION

The “class of operation” describes how the tube(s) (in any configuration) are “biased to operate”: are they Class A, Class B or Class AB? (There is even a Class C although it’s used for high power radio transmission, not audio.) “Biased to operate” simply refers the various voltages on the tube(s) and how they relate to one another, especially the negative “bias” applied to the grid. These voltages determine how much electrical current flows through the tubes both when they’re amplifying and when they’re “idling”, waiting for you to play a note. Thus the “class of operation” (determined

The “class of operation” (determined by the voltages present) is totally separate from how the tubes are arranged and every amp circuit has BOTH a class and a configuration.

by the voltages present) is totally separate from how the tubes are arranged and every amp circuit has both a class and a configuration. Since pre-amp circuits are always run single-ended and Class A, when we speak of other classes and configurations we’re generally referring to the power sections of amplifiers where the horsepower is generated to drive the loudspeaker. That’s where the hard work gets done and the output wattage is generated. Pre-amp signals, in contrast, amplify the signal voltage all right but the circuits are high impedance so very little current (or amperage) is involved.

SECOND DIGRESSION

Let’s quickly describe the difference between voltage and amperage. Voltage measures the “energy level” (like pressure) and amperage measures the quantity. Both must be present in some degree to comprise any electrical current, but they can exist in wildly different proportions. Here are two examples: Everyone is familiar with a static electricity shock you may get when walking across a carpet

and touching a door knob. The charge you pick up can exceed 100,000 volts! That's not a typo – and 100,000 volts is in the range of high-tension power transmission lines! Fortunately, there is almost zero amperage (quantity of electrons) or you would burst into flames and die. This much high voltage can charge up because of the extremely high impedance of dry air: there is virtually no load on your body to drain the static (“not moving”) charge. Contrast that example with the battery in your car. It's only 12 volts, so you could touch both terminals without feeling anything. Yet the battery can produce lots of current – a thousand amps or more – to turn over your engine. Those may be low voltage electrons but there are so many of them, the battery cables must be thick to handle the high-amperage current. Power is measured in watts and they are the product of multiplying volts times amps.

Pre-amp signals in vacuum tube amplifiers are mostly “voltage” ranging from the 1 volt or so your guitar puts out to as much as 100 volts of massively overdriven signal. However, the current remains very low, around a milliamp more or less (a thousandth of an amp), so like the static electricity, there is almost no power involved. However the power needed to drive your speaker to 100 watts is 20 volts times 5 amps, closer to the car battery example. So you can see that producing output power is a whole different job for the tubes than merely boosting up a pre-amp signal. And that's why the other configurations and classes were developed. And why an output transformer is needed.

CLASS 'A' POWER AND CATHODE BIASING

You often hear of “Class A” referred to with special reverence, as though it possesses some mystical powers of musical magic. And maybe for some styles, it does. Class A power always seems to sound warm, smooth and natural – even when it's pushed to clip and sounding brash

and rebellious. Some players describe the feeling as juicy and dynamic as well. Class A is the oldest, simplest and least expensive way to wire power tubes. But Class A also

Class A power always seems to sound warm, smooth and natural—even when it’s pushed to clip and sounding brash and rebellious.

runs the hottest, and is the least efficient, least powerful way to operate tubes. And that’s why so much development was aimed at circumventing the inefficiency of Class A power. (Maybe it’s all that waste heat that accounts for much of the tonal warmth!)

The reason why it’s the simplest, oldest and cheapest way to operate power tubes is because it generally doesn’t require a “bias supply”. That’s an extra power supply separate from the Main High-Voltage supply that ultimately powers the speakers. The bias supply produces a negative voltage (around -50 volts for 6L6s) and enables “Class AB” operation of the tubes where they run cooler and put out much more power than Class A. Virtually all guitar amplifiers operate in either Class A or Class AB and we’ll get to the differences between them in a moment.

Meanwhile, back to the historical roots. Any power supply, including a bias supply, requires a rectifier to convert the AC wall current to DC, plus a few resistors to set the proper voltage and some filter capacitors to smooth out the DC. AC is any current where the voltage is fluctuating; DC is steady state current, as from a battery. Because it’s fluctuating, AC can be “transformed” through transformers to alter the voltage-ampere ratio (or the phase, as we’ve seen). Though Edison gets most of the credit for bringing electricity to the cities, he stubbornly (and incorrectly) advocated DC. Nikolai Tesla saw the virtue of AC: It allows high voltage power transmission over great distances with little loss that can be stepped down along the way to a level safe for domestic use. The rivalry between these two men was so fierce that Edison “invented” the electric chair, us-

ing AC to show how deadly it was. Unfortunately, it failed to kill the first poor victim until the third try! (Hey, I've been shocked by both AC and DC high voltages but I honestly failed to detect any significant differences in how they felt!)

In the old days, rectifier technology was primitive and expensive, usually requiring a tube, though selenium rectifiers were often used, even if they were almost as cumbersome, expensive and unreliable. Now we have reliable silicon diodes that do a "technically superior" job of converting AC to DC for pennies. (I add the emphasis because we have a patent on amplifiers that feature switchable rectifiers to showcase the musical differences between vacuum tubes and silicon diodes. That feature is included in both Lone Stars as well as the famed Dual Rectifier models. But we'll go in-depth on the rectifier topic another time.)

For so-called Class A operation, the entire bias supply can be eliminated (saving a lot of expense) and a simple resistor connected between ground and the power tubes can serve for biasing. It's really more accurate to call these circuits "cathode biased" because they're probably not always going to be Class A, despite that preferred description. But the distinction is a technical one and far less important than the sex appeal attached to calling an amplifier "Class A" – with its implication of being the very best. And that will always out-class "Cathode Biased" even though both terms are commonly used to describe the exact same thing! Note that Class A can also be derived using a separate fixed bias supply though, for guitar amps, it almost never is.

SO WHAT IS CLASS A?

What Class A really means is that "Grid bias and alternating grid voltages are such that plate current in a tube flows at all times". Got that? That's the entire definition from the RCA Tube Manual: the Ultimate Authority itself. I've pondered that statement for decades and have

concluded that it's both simpler and more complex than it appears.

To make it simpler, think of a tube in the British sense: It's a "valve", mate. All Class A means is that the valve would never shut off all the way. Some amount, even a trickle would always be flowing through it. (How sexy is that?)

In a vacuum tube, electrical current – like a fog of water droplets – flows from the hot cathode (that central core with the glowing filament inside) to the plate (or "anode") that big metal structure just inside the glass. In between the cathode and the plate is the grid, a spiral coil of fine wire with plenty of space between the turns. The grid acts as the control element (like the handle of the valve) by regulating the electron flow from cathode to plate. Here's how:

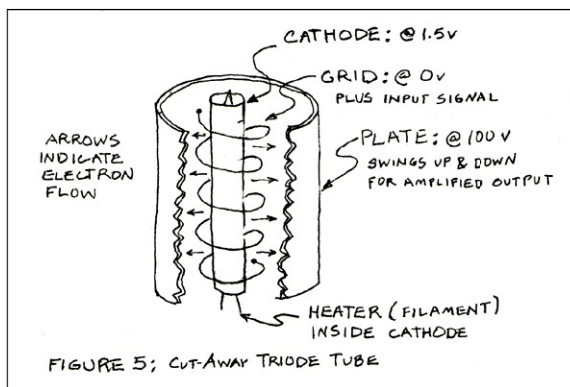
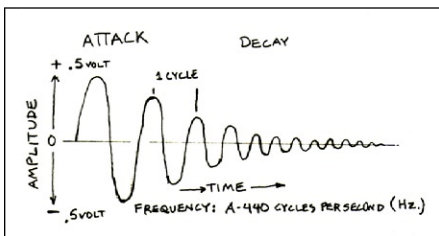

FIGURE 5 shows a triode vacuum tube, such as a 12AX7. The cathode has an electron-rich coating and is heated by the filament inside. Electrons boil from its surface and form a cloud around the cathode. These negative electrons are strongly attracted by the positively charged plate. But in between lies the grid and it is biased to be slightly MORE negative than the cathode. Thus it repels many of the electrons. In Class A, the balance between these two opposing forces is set (or "biased") so about half of the electrons flow between the turns of the grid wire and make their way to the plate at idle. Altering the voltage on the grid slightly causes a big variation in the number of electrons that can pass through –and that's how amplification works!

to flow at idle and the tube is said to be “cut off”. (The “valve” is turned all the way off.) The negative influence of the control grid is so strong that no current flows until you start to play a note. But in Class A, there is lots of idle current flowing, optimally 50% of the maximum possible. (You’ll see why later.)

Now the “alternating grid voltages” of the RCA definition are merely the incoming signal voltages from your guitar that the tube is going to amplify. It’s YOU playing. Your touch on the strings is what’s generating the original “signal voltages” that your amp delivers to the speaker. These “alternating voltages” are made up of “frequency” (say A-440) and “amplitude” which is loudness. Pluck an A note hard and about 1 volt comes out your guitar. As the string vibration decays and the note gets softer, the voltage dies down, but it still alternates 440 times per second. Now it’s more accurate to think of that 1 volt AC signal as alternating between “plus 1/2 volt” and “minus 1/2 volt” since that’s what’s generated as the string vibrates back and forth over the pickup.

When that alternating voltage swings positive and is added to the first pre-amp tube’s grid, it counteracts some



of the negative bias voltage there, making the grid less negative and allowing more current to flow to the plate. When the guitar’s output voltage swings negative, it adds to the already negative grid voltage, increases the repellant

force field of the grid and further reduces the current flow to the plate. And that, Ladies and Gentlemen, is how the valve ...uh tube, works. Pre-amp tube or power amp tube, it’s exactly the same except for the size.

Class A would simply be a set of operating parameters such that the valve never shuts off completely and some amount of current, even if it’s just a trickle, is always flow-

ing through it. This is the best part of Class A operation because it's when a tube stops and starts – cuts off then resumes conducting current that most distortion or “non-linearities” – occur. And distortion, to the RCA engineers, was Bad. In their world, amps were never intended to be turned up into distortion. But even the most Class A amp, if turned up loud enough, would go beyond Class A and into cut-off. At some point those “alternating grid voltages” (that’s the signal, which increases with loudness) will add so much to the “fixed bias voltage” and create such a strongly negative field at the grid, that current will indeed cease flowing. In radios and hi-fi’s, designers can assume you’ll never turn it up into heavy clipping because it sounds so bad. Thus they can say an amp is always Class A because they can predict the maximum input signal. Then there are guitar amps. No such prediction can be made and in fact the opposite is true. Huge signals are purposely used to create overdrive and distortion. Those poor old engineers would be shocked and stunned at what we do to their tubes! And in the name of music, no less! I’ve hung out with some of these old guys and indeed, they were appalled, once they got over their disbelief! (Try describing an amp spewing out a barrage of hard-core krang to a guy whose only exposure to guitar is campfire folk songs!)

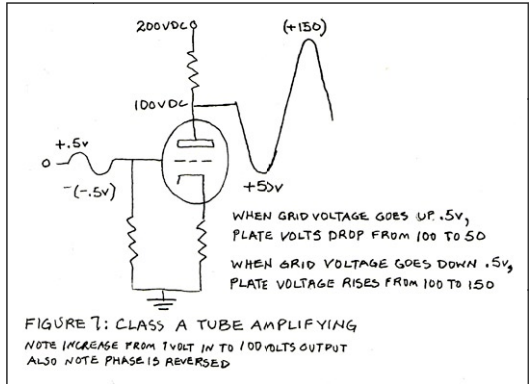

FIGURE 7 shows the same tube under dynamic conditions. As the input voltage swings positive, it reduces the repelling force the grid had at idle. More electrons then stream to the plate, loading it down and causing a bigger drop through the plate resistor. This “drags down” the voltage on the plate from 100 to 50 volts. When the grid swings negative, the effect is reversed. The grid repels more electrons and causes less of a drag (or drop) through the plate load resistor allowing the voltage on the plate to rise to 150 volts. Thus the 1 volt input signal has now caused a 100-volt change at the plate. By coupling this “fluctuating DC” through a capacitor or transformer, the DC component is blocked and only the fluctuations remain as a pure AC signal of 100 volts, or, + and - 50.

assume you’ll never turn it up into heavy clipping because it sounds so bad. Thus they can say an amp is always Class A because they can predict the maximum input signal. Then there are guitar amps. No such prediction can be made and in fact the opposite is true. Huge signals are purposely used to create overdrive and distortion. Those poor old engineers would be shocked and stunned at what we do to their tubes! And in the name of music, no less! I’ve hung out with some of these old guys and indeed, they were appalled, once they got over their disbelief! (Try describing an amp spewing out a barrage of hard-core krang to a guy whose only exposure to guitar is campfire folk songs!)

HOW AN AMP WORKS

Now let's discuss something pretty basic that confuses a lot of musicians. In an amplifier, the weak little voltage from your guitar is not really “built up” to something that can drive a loud speaker. Rather, there is a big High Voltage Power Supply in every amplifier and that is the source of the juice that makes your speaker move. Think of it as a jumbo battery. And like a battery, it's a DC power

source, steady and unwavering.

What the amplifier does is “modulate” the power from that supply through the speakers in accordance with your guitar signal. It's that same current flow we were just talking about. And in a way, amplification is like converting DC to AC (the opposite of “rectifying”). Play a soft A-440 and the output valves in your amp let a little of that DC current flow from the supply through to the speaker,

440 times per second. (Now it's 440 Hertz Alternating Current.) Play a loud A and the tubes allow a lot more current to flow, still at 440 Hz. Now that's basically how tube amplification occurs – and it is like a valve! Think of the chain of pre-amp tubes as working like a sequence of levers hooked up one to another so at the end there is finally enough “leverage” to open and close the big power valves.

“So, what about the ‘Class A’ bit”, you ask. “If Class A means current always flows, why don't I hear anything when I'm not playing”.

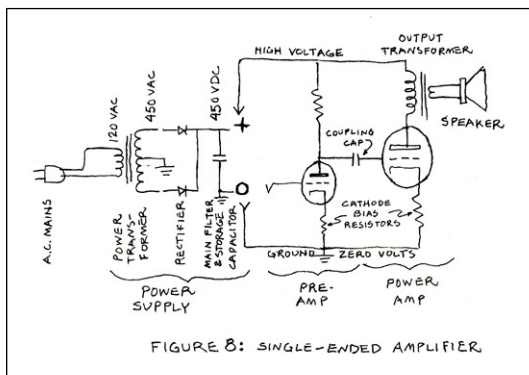

FIGURE 8: SINGLE-ENDED AMPLIFIER

FIGURE 8 shows a complete but very simplified single-ended amplifier. The power supply consists of the transformer to boost the 120 AC wall voltage to around 450; the rectifier to convert the AC to DC; the main filter capacitor to smooth the DC and provide a reservoir of current. Juice flows from this main high-voltage power supply through the power tube and its output transformer. Fluctuations in current flowing through the output transformer are coupled to the speaker as useable output power. The pre-amp increases the guitar signal to a level sufficient to drive the power tube.

Good question. Here's the answer: at idle, the current that's flowing is pure DC, direct current, steady and unwavering. And the "output transformer" coupled between your power tubes and your speaker does more than "transform" the different impedances of the tubes and the speaker so they match each other. It also blocks the flow of direct current.

Put another way, the output transformer only allows the fluctuations in current flowing through its primary (input) winding to be coupled through the magnetic field of its iron core and to induce a current at the secondary (output) winding connected to your speaker. Any current flowing through the primary winding that is steady and unwavering, as is DC, produces no current at the secondary.

Look at the picture. You've got this big DC power source coupled through the output tube and the transformer primary winding. The power tube functions like a valve turning a little more ON then a little more OFF, 440 times a second for the soft note. And turning a lot more ON and a lot more OFF for the loud note. In this way the amount of high-voltage DC current flowing through the primary is modulated, or fluctuated, 440 times per second. On the secondary side only the fluctuations appear as 440 cycle Alternating Current without the high-voltage DC component. Again, that's amplification! Only this time it's power amplification and it's "transformer coupled". So the output transformer does three important things: It is an "impedance matching device" converting the high-voltage-at-low-amperage required by the tubes into low-voltage-at-high-amperage required by the speaker, it converts from push-pull to single ended, and it blocks the flow of DC current. Moreover, the output transformer is a crucial part of an amplifier's sonic personality. One of the first

The "output transformer" coupled between your power tubes and your speaker does more than "transform" the different impedances of the tubes and the speaker to match each other. It also blocks the flow of direct current.

transformer engineers I was fortunate enough to work with was a real old guy who said, “Son, output transformers are half science and half black magic. But it’s the black magic that counts!” How true!

IDLE CURRENT

The Classes of Operation have just as much to do with the idle state as with the actual amplification itself. Consider Class B, because it’s easy to picture. In Class B, the bias is set so no current flows when there’s no signal. Thus no power is being consumed and no heat generated. (Think of this as “zero idle RPM”.) Then when a signal voltage hits the input grid, the positive half-cycles turn the tube ON, it begins to conduct current from the power supply directly into the load (usually a transmitting antenna) and very efficient power amplification takes place. It’s a bit like an electric golf cart or a new hybrid car. The motor stops turning when you stop the cart. When you want to go, the motor starts right up again. It has its range from Off to Maximum. But to get going, you have to first turn on the current because none flows at idle.

Then there is Class AB. This would be like having the motor go to a low RPM idle when you’re stopped. It’s still turning over (some current is flowing) but not nearly the maximum available. You could let out the clutch and putt around but only at a slow-to-moderate speed. But to get fast (or loud), you have to increase the total current flow – not just cause it to fluctuate. The loudness at which the total current begins to increase is the transition into Class B. In many ways Class AB is the best of both worlds for audio and it’s how the 6L6 Lone Star, the Rectos, Stilettos and most Fenders and Marshalls operate. Its high efficiency makes it the pinnacle of power for clean, cool audio.

Then there’s good old Class A. In a single-ended, pure Class A power circuit, the current runs at 50% of maximum even at idle when there’s no incoming signal. Then

when a small signal voltage hits the input grid, it causes the current flow to fluctuate up and down between, say 60% and 40% of maximum. A louder signal would cause greater current fluctuations, say between 80% and 20%. And the maximum undistorted signal output would occur when the input signal drives the tube so it conducts a current that fluctuates between 100% and 0% at the A-440 or whatever the input signal frequency is.

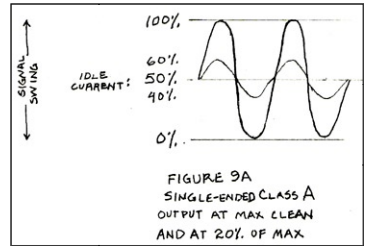

Notice how the current fluctuations in a proper Class A amplifier are always centered around the mid-point, that 50% of maximum which is the same as the idle current. What this means is that there is no net increase in the current flow like there is in Class B or AB, no matter how loudly you play. In a single-ended configuration, the increases and decreases in current flow are momentary (at the signal frequency), equal and opposite around that 50% mid point. At one instant of the A-440 there will be more current flowing, but in the next instant there will be an equal amount less flowing. Thus the total over any period of time remains constant.

Now in a pure Class A, Push-Pull amplifier, 100% of the maximum current flows at idle, 50% through each side. When an incoming signal causes fluctuations, the current in one side of the push-pull increases from, say 50% to 70% while current in the other side simultaneously decreases from 50% to 30%. The two signal halves alternately offset each other so the total current flowing through the output circuit remains the same at 100%. (Not all, so called, Class A amplifiers work so perfectly balanced right up to – and well into – clip, but the Lone Star Special does. You can measure the current flowing through the output tubes and it never changes whatever the signal.) Remember, only the fluctuations in current are transferred as useable energy to the speaker.

DISSIPATION

Notice how in the Class A example, the current swings are always centered around that mid-point idle current which is 50% of maximum. This is called “biased around the mid-point of the linear region”. That’s the vital for low distortion. The other classes of operation, Class B and Class AB are definitely not biased anywhere near that mid-point and that’s the key to their ability to run cool and produce more power.

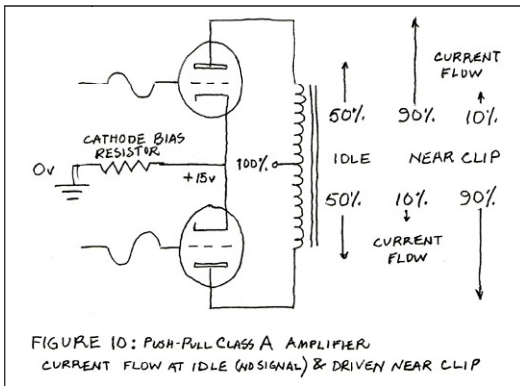

FIGURE 10 shows the current fluctuations of Push-Pull Class A operation. Total current remains at 100% under all conditions. At idle, the current is split 50-50 between the push-pull halves. When driven by a signal, current flowing to one side increases but is simultaneously offset by an equal decrease in current to the other side. This “back-and-forth” increase/decrease action alternates at the signal frequency A-440.

Remember earlier how one big disadvantage of Class A is that it runs so hot and is so inefficient? Here’s a new word for most of you: “dissipation”. (And I’m not talking about the Keith Richards type of lifestyle!) Dissipation is wasted power that the tube turns into heat. To use the car analogy: Class A idling is like having the engine running wide open with the brakes locked and the clutch

slipping. All the engine’s power is being wasted and “dissipated” into heat. To get some useful output, you would have to let up on the brakes, not completely, but enough to get the car moving. Then there would be less total slippage (or dissipation), even though it’s now shared between the clutch and the brakes – which are dragging but not locked. But now you’re getting some useful work from the engine’s power, in the form of motion, instead of just waste heat. Engine power – in any amount that’s used for moving the car – reduces the dissipation by that same amount because there is that much less total slippage at the clutch

and brakes. At full speed ahead neither the clutch nor the brakes would be slipping. Nearly all of the power would finally be converted into motion (or sound) with virtually no dissipation through slippage friction. But just as you can't drive your car at full speed all the time, the highly dynamic nature of music means that Class A amps spend most of their time dragging and slipping. There are only briefly dynamic peaks where most of the energy actually goes to the speaker.

To recap: Class A amplifiers, single-ended or push-pull, suffer from maximum dissipation at idle. All the steady state DC power passing through the tubes goes up in heat. Only when that power fluctuates (like at A-440) does some of it convert to useful audio power to drive the speaker. Power that flows through the tubes and drives the speaker is power that is not dissipated as heat. Yet the dissipation rating of a tube is what limits its power capability much more than the useable power that can pass through it. Like the clutch analogy, it's the slippage converting energy into dissipated heat that kills it, not the power flowing through it when it's fully engaged.

Long before Class A power became sexy in the retro-vintage sense that we all dig, the direction of amplifier technology was to deliver more power with greater economy. There was no mystique about Class A, only an awareness of its shortcomings and a desire for more clean horsepower with less waste heat.

Other classes of tube operation were developed to do just that. Class B and Class C are both highly efficient and cool running, and work great for radio transmitters where vast amounts of power are required. These classes are biased so there is virtually no idle current, and nearly all of

Power that flows through the tubes and drives the speaker is power that is NOT dissipated as heat. Yet the dissipation rating of a tube is what limits its power capability much more than the useable power that can pass through it.

the juice passing through the tubes is converted to useful output.

Unfortunately, those classes aren't suited for audio: Too much distortion caused by that "turning on and off" phenomenon. So designers in the late 1930's started to come up with an exciting new configuration that helped overcome the waste of a Class A operation and the distortion of Class B. It's the "push-pull" we've been talking about and it makes possible Class AB operation with high efficiency and low distortion.

CLASS AB

Here's where "class" and "configuration" really work to each other's advantage. The push-pull configuration with its balanced operation makes Class AB possible, and what a great thing that is. Here's why: We've discussed how single-ended Class A requires that the tube be biased to conduct 50% at idle. We talked about how a push-pull pair of power tubes running Class A should be biased so each one conducts 50% at idle (so there's no real advantage in terms of power or dissipation.) And we've mentioned Class B where there's no idle current or dissipation because the tubes are biased to cut-off, generating too much distortion for audio.

What Class AB does is fill in the "gap" in the middle of Class B push-pull operation. It eliminates the cut-off by insuring that some current flows during idle and throughout the transition from one side of the push-pull to the other.

Earlier we used the shower faucet analogy with separate Hot and Cold valves to illustrate how current flows in push-pull. Well, now imagine that you can link the valve handles together with a rod so both valves turn when you move the rod back and forth.

Let's say moving the rod left increases the Hot and decreases the Cold. Shoving the rod right does just the opposite. Class B push-pull would be set up so that with the rod

in the middle position, no water would flow. Pushing it left would turn on the Hot and have no effect on the Cold, since it's already off. As you moved the rod back to the right, all flow would stop momentarily as you passed the center – that's the idle point – then the Cold would start flowing. That dead spot in the center represents the distortion caused by cut-off.

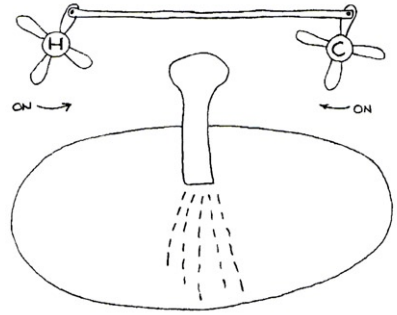

Here's something you can try at home if you have the right kind of opposite-turning valves.

For Class A push-pull, picture the Hot and Cold valves each turned half-way on before they're linked together. Now moving the rod back and forth doesn't vary the total volume of water, it just changes the mix of Hot and Cold. The fact that you can no longer turn off the water represents the waste of Class A dissipation.

And for Class AB push-pull, both Hot and Cold would be on a little bit in the center position but able to dramatically increase the total flow when the rod is moved far to the left or right. The dead spot is eliminated and waste water is greatly reduced. These are the advantages of AB push-pull operation.

In electronic terms, Class AB push-pull is like two a-symmetrically biased amplifiers that mirror image each other. At idle, both are turned on around 10% to 30%, as determined by the bias setting. Because they are biased closer to OFF than ON, they run cool. They also have the potential to turn ON much more than they can turn OFF because at idle, they are nearly off already. For small signals they work just like a Class A amplifier: merely modulating the idle current flowing through them, neither turning off nor requiring an increase in input power.

But as you play louder, the Class B a-symmetry begins to show. Each side of the push-pull alternately turns way more ON than off, causing the current to increase

first through one side then through the other. And as the opposite side – the one with the diminishing current – approaches cut-off, the "on-going" side has already entered its linear region and can take over while avoiding the distortion around cut-off. Providing such a Class A zone of overlap between the push and pull halves of a Class B amplifier allows the transition to occur smoothly by eliminating the "dead spot" in the middle. And the reduction of wasted dissipation is huge. Check out the waveforms shown below to understand the concept of "a-symmetrical" operation.

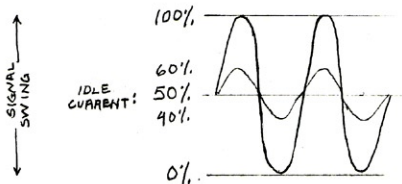
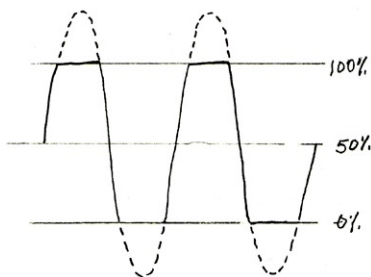

FIGURE 9A
SINGLE-ENDED CLASS A
OUTPUT AT MAX. CLEAN
AND AT 20% OF MAX.



9B: SYMMETRICAL CLIPPING
FROM 9A AMP OVERDRIVEN

Figure 9A shows a Class A output right at the maximum clean possible. The circuit is "biased about the midpoint of its linear region" as we've said before and current fluctuates symmetrically between +50% and -50% for a total 100% of what's available. Biasing at the midpoint means the tube is running hot and wasting most of the power except when driven to max. The waveform of 9B shows the same amplifier driven beyond max and into clip. It's input signal is telling the tube to conduct more than 100% and since it can't do that, it distorts. The dotted lines show the "clipped" sections that are missing. The circuit is still symmetrical, being biased to operate around that midpoint.

Figure 9C shows the tube biased far away from that hot midpoint. It can still conduct the same total amplitude (height) of waveform but doing so a-symmetrically causes it to run out of excursion in one direction and clip early. Any signal above plus-and-minus 10% is going to drive the lower half of the waveform into clip. This is the price you would pay for running the tube nice and cool with

very little dissipation at idle! It's almost as bad as what a single-ended Class B waveform looks like and you can see why it's no good for audio.

But if we add another tube in its mirror image for push-pull, we can combine the waveforms as shown in Figure 9D. The zone from plus-ten to minus-ten percent represents the Class A portion where current flows through both tubes. Signals beyond that level will drive each of the tubes alternately into cut-off with the remainder of the signal being amplified by the other tube, again at the A-440 or whatever frequency.

Now, if you're still with me, here's the real big benefit. Since we've reduced the idle current (amps) by biasing the tube away from that midpoint, we can now substantially increase the voltage and still keep the dissipation at a level well below what it was for Class A. And as the voltage on the tubes increases, so does the amplitude or amount of clean power they can conduct. It can go way up.

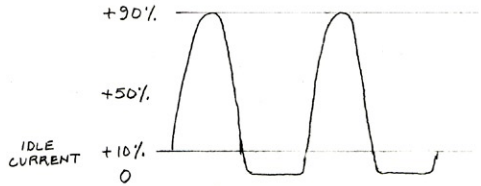
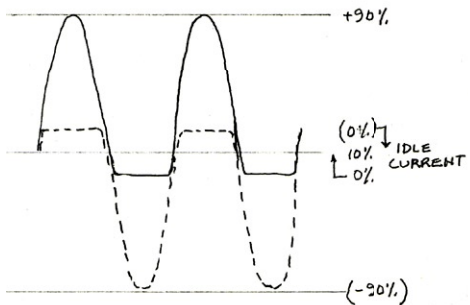

FIGURE 9C: SINGLE TUBE
A-SYMMETRICALLY BIASED
(NOT CLASS A, RUNS COOL
BECAUSE BIASED NEAR CUT-OFF)



9D: COMPOSITE OUTPUT
FROM PUSH-PULL PAIR
OF TUBES BIASED AS 9C
FOR CLASS AB

POWER AMP DISTORTION

Distortion in an amplifier increases dramatically when the input signal is so large it tries to tell the tube to conduct more than 100% or less than 0% of the current available in the high voltage supply because, of course, it can't do so. This type of overdrive distortion can, and does, occur in power or pre-amp circuits when they're driven

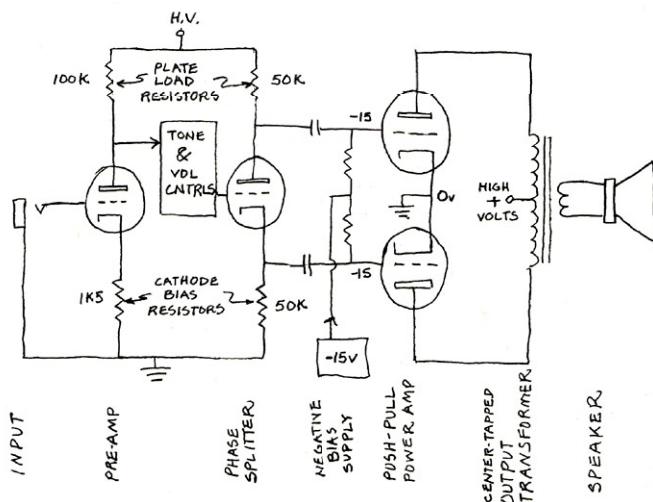

FIGURE 11: AMPLIFIER WITH "CLASS A" PUSH-PULL OUTPUT

FIGURE 11 shows a simplified push-pull amplifier. Compare the resistor values in the pre-amp and phase splitter tubes. In the pre-amp the ratio of 1K cathode to 100K plate would give a theoretical gain of 100 times. By using identical 50K resistors in the phase splitter's plate and cathode circuits, there is no amplification "gain" but rather signals of equal amplitude and opposite phase appear at plate and cathode to drive the push-pull power tubes. High voltage DC is fed to the power tubes through the center tap of the output transformer. A separate bias supply enables the tubes to operate "asymmetrically" for Class AB. Performance would be as shown in waveform 9D. When clipped, the waveform would be the same as shown in 9B.

hard and especially when they're equipped with extra gain to provide intentional overdrive. A typical overdriven and clipped waveform is pictured in Figure 9B.

In power output stages, what usually happens before the power supply runs out is that the power tubes themselves reach maximum capacity, literally running out of room on the insides of their plates. So much current is flowing that the entire inner surface is saturated and the extra electrons arriving there have no place to "stick". This is why we can raise or lower the output capacity of the amplifier by switching additional tubes in or out.

Authentic retro tone is all about power and the way it clips. Yet in any given amp, the sweet-spot of power clip is inseparably tied to its wattage and playing loudness. The two Lone Stars smash this age-old limitation by giving you

distinct and switchable power configurations, each with its own window of wattage for genuine power tube clip, beginning at 5, 15, 30, 50 or 100 watts, depending on the amp and its setting. And these are channel-assignable, so each can be tailored for the tone and power you want.

Switching out pairs of power tubes is something I first came up with around 1969 for a Marin County band called Flying Circus. Bill Graham's "3-Band" policy for the Fillmore was that the opening band had to share their gear with the second band to avoid lengthy stage changes. Circus had just put new JBL's in their Twins and worried that the hard-rock band that followed them would blow up the new speakers. So they asked if I could come up with a way to secretly reduce the power before their rivals took over. And turning off one pair of 6L6s on each amp via switches I had hidden under the chasses did the trick. We later discovered the musical virtues of power tube switching (because they forgot to turn all four back on!) and have used it in many different amps since then, finally making it channel assignable in the two Lone Stars (patent pending).

DISTORTION CHARACTERISTICS

Another kind of distortion occurs as a result of "cut-off" (current ceasing to flow) at the transition between pushing and pulling. This "cross-over" or "notch" distortion sounds fairly brash and searing; it's comprised of the higher odd-order harmonics.

A Marshall with EL-34s that is biased too cool will produce much more of this notch distortion than will any Fender with 6L6s, so part of it is the intrinsic differences between the tube types. Decreasing the bias (making it less negative) extends the Class A zone at the transition and will usually soften or eliminate this situation at clip. However in EL-34 amps, the notch may reappear when the power amp is heavily overdriven as a result of the huge signal voltage totally overwhelming the negative grid bias and actually

driving the control grids positive. This is called Class AB2 operation. When it happens the control grids themselves begin to draw current from the cathode, though it does not become useful power to drive the speaker.

You may think that the reverence for Class A would suggest that the lower you set the bias, (and therefore the more Class A an AB amp runs) the better it will sound. Not true. While the measured distortion will continue to fall as bias

...all Mesa/Boogies come with the bias permanently wired to the correct setting, to maintain this sweet spot within our range of power tubes.

is reduced, the sound for guitar amps, at least, passes through a “sweet spot” and begins to lose its sparkle and liveliness. This is one reason why all Mesa/Boogies come with the bias permanently wired to the correct setting to maintain this sweet spot within our range of power tubes.

One of the most interesting features of the Lone Star Special is that ability to switch configuration from push-pull to single-ended. (This is a lot trickier than merely turning off more tubes. We have a patent pending on how it’s done.) Don’t forget that push-pull, like balanced operation, cancels out anything that is common to both sides.

And that’s exactly what happens to the second distortion harmonic: It gets cancelled out and disappears. “Second harmonic” is the technical name for the distortion component one octave above the fundamental note that generates it, when clipping. Not only is it the most predominant distortion element produced by the tubes, but it’s also the warmest and juiciest because of its simple musical consonance. However that second harmonic content is entirely eliminated in push-pull circuits by the same cancellation process that eliminates noise from microphone cables. In technical terms this was the original reason for running Class A in a push-pull configuration, lower distortion. Any benefit in terms of power or dissipation only occurs in Class AB push-pull. Looking at it all together,

you can see why Push-Pull AB is the pinnacle of power for audio: Huge increases in power and efficiency plus the biggest component of the distortion spectrum completely eliminated! Wow! Such a Deal.

In musical terms though, the distortion reduction is less significant because that second harmonic is so musically consonant that it doesn't so much sound like a grating crackle (like the higher order harmonics) but more like a sweetening and softening of the original note since what is added, is the same note an octave higher, at some percentage (say 3% to 20% or so) of the fundamental. A perfect example of technical measurements being misleading compared to sonic reality. (Meanwhile a small proportion of 5th, 7th or higher harmonics is definitely noticeable and sounds buzzy, thin and grating.)

The predominant distortion harmonic remaining in a push-pull circuit is the third, which is an octave and a fifth above the fundamental. This is still fairly consonant musically and can actually help the amplifier punch and sting its way through a band's mix. Switching the Lone Star Special between 5 watts single-ended and 15 watts push-pull will reveal these subtle but noticeable differences between the distortion signatures of the two configurations. Five watts is subtle, precious and nuanced – perfect for individual playing or recording. Fifteen watts push-pull is bright, chimey and punchy – altogether better for cutting through a band's mix.

“Second harmonic” is not only the most pre-dominate distortion element produced by the tubes but it’s also the warmest and juiciest because of its simple musical consonance.

SIMUL-CLASS POWER

Here's something you won't find in any textbooks, although you will find it described in our US Patents 4,532,476 and 4,593,251. Simul-Class is a push-pull parallel configuration where the parallel pairs are dissimilar.

It's really two separate and different push-pull amplifiers that may be operated individually or "Simul-taneously" each in different "Classes", through a common output transformer. One pair of tubes is biased to operate Class AB while the other pair is biased to run Class A. The Class A pair sets the sonic sound stage while the AB pair delivers the majority of the horsepower. Not only does the Class A pair of tubes go further in alleviating the "dead spot" during the push-pull transition, it also extends the region before current is cut off in the off-going section through the output transformer.

Simul-Class sounds smoother, warmer and less punchy than our standard Hundred Watt power. In short, it has more of the Class A characteristics.

That notch distortion mentioned earlier is exaggerated by the "back voltage" generated by collapsing current in alternate halves of the output transformer. Here's what that means: We've touched on how a transformer only passes fluctuations in current, not steady-state DC flow. Well, when the power momentarily and alternately shifts (again at A-440)

and all flows through one half of the output transformer, current may be momentarily cut off for the other half when driven hard. The magnetic field stored in that half of the transformer iron from its DC current "collapses" when that current suddenly ceases to flow, and as it does so, the magnetism converts back into voltage. That becomes yet another distortion component. (To return to the car analogy: The voltage used to arc across a spark plug is generated the same way. When the charge is removed from the ignition spark coil, the stored magnetism converts instantly into a spike of output voltage which is used to ignite the fuel mix in the engine.)

By now you know that Class A is only meaningful as a combination of fixed bias and signal voltage (loudness), so Simul-Class allows the push-pull amplifier to remain above the cut-off point while handling a larger signal. Even

though the Class AB pair have stopped drawing current, the Class A pair continues to maintain some current flow through the transformer primary, preventing a collapse of the magnetic field and that resulting back voltage.

Many Simul-Class amplifiers also ran the Class A pair wired for Triode operation. This means that the screen grids of those two tubes are wired to the plates and are functionally disabled. Think of the screen grids as accelerator elements, working like a catalyst to increase the tube's sensitivity to incoming signals. With the screens disabled, the resulting Triode response has a much more gradual reaction (a lower "power sensitivity") to incoming drive signals, causing a softer onset of clip. The sonic response is somewhat comparable to using your fleshy thumb to pluck a string as compared to the harder edge of a pick. The note is still the same frequency and may be just as loud, yet the harmonic content, and hence the timbre, is entirely different. Triode operation also reduces the tube's power handling capability by about half.

Simul-Class is found today in our Mark IV and Stereo 2:Ninety amplifiers and has its precedent set in the hallowed Mark II-C's of yesteryear, some of Metallica's favorites. Simul-Class power sounds smoother, warmer and less punchy than our standard Hundred Watt power. In short, it has more of the Class A characteristics.

MILES AND COLTRANE

This techno-rap could go on forever. It's hard to know how or where to end. In fact, it reminds me of a story from the late days of the great Miles Davis Band when John Coltrane would regularly play solos lasting 20, 30, 40 minutes or more. When Miles complained to Coltrane about this, Trane replied, "There's still more to say, man. I don't know...How do you end a solo?" To which Davis replied slowly, "...You take the horn out of your mouth."

THE END
(for now, at least)

————— MESA PATENTS —————

Original Lead/Rhythm Dual Mode Amplifier 4,211,893

Simul-Class Power Amp 4,532,476

Simul-Class Power Amp 4,593,251

Lead/Rhythm Dual Mode Amplifier (Simplified) 4,701,957

Dyna-Watt Power Amp 4,713,624

Tweed & Spongy Power - Mains Voltage Reduction 5,091,700

Selectable Dual Rectifier 5,168,438

TriAxis Preamp – Programmable Midi Control of 8 Tube Modes 5,208,548

Progressive Linkage - Variable Power Tube Power Section 5,559,469

Parallel FX Loop with Mix Control 6,522,752

Mute Circuit 6,621,907

Solo Control – Pre-settable, Footswitchable Volume Boost 6,724,897



The Home of Tone, Petaluma, California – Good Ol' USA

